

WOODCRAFT CFMOTORSPORTS

105 Baldwinville Rd
Winchendon, MA 01475
(978)297-2977

www.woodcraft-cfm.com

05-0409 Yamaha FZ09 Rearset Instruction Sheet – Racing Use Only

Thank you for selecting CFMOTORSPORTS rearsets. Please note that these components are intended and approved for **racing use only**. As such, the footpegs are solid-mount and provisions for brake light switches are not provided with the kit.

- 1) Remove stock rearsets, footpegs and associated hardware. All components that are re-used in this kit should be cleaned and inspected for damage before re-installation.

IMPORTANT

Tighten all fasteners to factory specification or industry standard. **FAILURE TO PROPERLY TIGHTEN ALL FASTENERS MAY CAUSE DAMAGE TO THE MOTORCYCLE, LOSS OF CONTROL AND SERIOUS INJURY OR DEATH**

Shift Side Assembly Installation

- 1) Bolt the CFM footpeg to the bracket using the included 10mm hardware. **IMPORTANT** - Secure bolt with LOCTITE.
- 2) Assemble the CFM shift pedal **IMPORTANT** - Secure bolts with LOCTITE. Attach the heim joint to the pedal using the included hardware and spacer. Refer to the photos below for the GP or Std shift orientation.
- 3) Assemble the main shaft to the CFM shift pedal. **IMPORTANT** - Secure all bolts with LOCTITE. Attach the pedal to the bracket using the 08-0409P pivot, hardware and wave washer. Be sure to apply quality v desired height using a combination of the included shift in place with the shift rod free-flow nuts.
- 4) Attach the 05-0640HGS to the bracket using the included bolts with LOCTITE.
- 5) Bolt the brake bracket assembly to the frame. The swingarm pivot bolt and OEM lower mounting bolts are re-used.

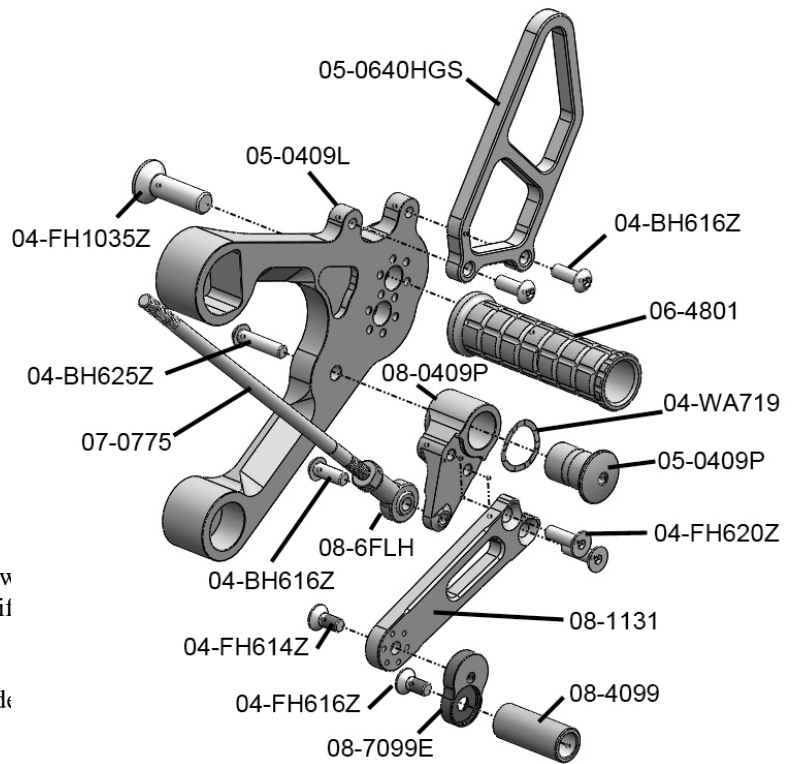

You must orient the shift pedal, shift rod and spline (the part on the engine) so that they are oriented as close to 90 degrees as possible for optimum shifting action.

Standard Shift



GP Shift



Brake Side Installation

Assembly

- 1) Bolt the CFM footpeg to the bracket using the included 10mm hardware. **IMPORTANT** - Secure with LOCTITE after you have selected your final choice for position.
- 2) Assemble the main shaft to the CFM brake pedal. **IMPORTANT** - Secure all bolts with LOCTITE. Be sure to apply quality waterproof grease to the surface of the 09-0409P brake pivot.
- 3) Attach the OEM brake pin (not shown) and hardware to the back of the bracket. **IMPORTANT** - Secure the 04-FH845Z bolt with LOCTITE.
- 4) Bolt the master cylinder and heel guard to the bracket using the 04-BH830Z bolts. Attach the master cylinder to the brake pedal using the stock hardware and adjust the brake pedal to your desired height using the eccentric offset plate and the OEM adjuster at the base of the master cylinder. **IMPORTANT** - Secure with LOCTITE after you have selected your final choice for position.
- 5) Bolt the brake bracket assembly to the frame using the OEM hardware.

NOTE: If you want to retain the OEM brake light function or to have a pedal return spring (not required for racing applications) Woodcraft has both of these parts available. The model uses the 03-0100 brake light switch (not shown) and the 09-7125 brake return spring (shown in assembly).

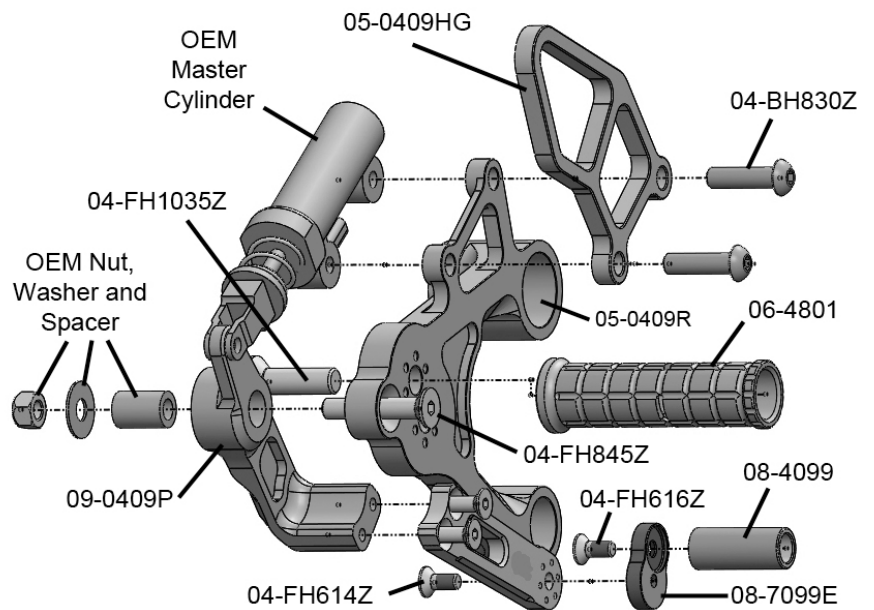

BE SURE THAT ALL COMPONENTS OPERATE AND RETURN FREELY BEFORE USE

If you have any questions regarding installation, please feel free to contact us.

IMPORTANT

Installation and use of this product will change the response of the motorcycle to rider control inputs. Failure of the rider to adapt to these changes may result in a loss of control, and serious injury or death. Improper installation and/or failure to comply with all warnings and instructions may cause a loss of control and serious injury or death. **DO NOT INSTALL OR USE THIS PRODUCT IF YOU ARE UNABLE TO DO SO IN COMPLIANCE WITH ALL INSTRUCTIONS AND WARNINGS. SEEK THE ASSISTANCE OF A TRAINED PROFESSIONAL TECHNICIAN.** Installation of this product releases the Woodcraft Technologies, Inc. from all liabilities as to the use of this product. The user recognizes that any alteration or modification to any motorcycle may increase the risk of injury or accident and may also render the motorcycle illegal for public road use